

Telguard Digital model TG-4

QUICK INSTALLATION GUIDE

Installation Summary

There are six steps in installing Telguard properly. **IF YOU DO NOT PROCEED IN THE ORDER AND MANNER PRESCRIBED, YOU MAY NOT COMPLETE THE INSTALLATION IN THE TIME ALLOCATED.**

STEP 1: REGISTER FOR CELLULAR SERVICE

Complete the Activation Form online at www.Telguard.com or fax the form to Telular Cellular Service prior to leaving for the job site. Telular requires this information to register and activate the unit.

STEP 2: LOCATE UNIT AND MEASURE SIGNAL STRENGTH (RSSI)

First, you will be confirming that Telguard has adequate cellular signal strength. Put J10 across both pins, LEDs will now indicate signal strength, minimum recommended is 2 1/2 (2 on solid and the third flashing).

STEP 3: TRANSMIT C/C ALARMS OVER THE TELCO CONNECTION

Once you have confirmed that the unit is active, you will be ready to verify that the C/C is programmed properly. This step is important to verify that the C/C is programmed with valid account code and central station information before transmitting signals through the cellular network.

STEP 4: PROGRAM, ACTIVATE & TRANSMIT C/C ALARMS OVER THE CELLULAR RADIO NETWORK

Next, you will be connecting the C/C's digital dialer output to Telguard and verifying that alarm signals can be reliably sent through Telguard over cellular to the central station digital receiver. The incoming Telco line is not connected to Telguard during this step. A minimum of two alarm signals must be transmitted.

(NOTE: THE FIRST ALARM WILL REGISTER THE UNIT WITH THE TELULAR COMMUNICATION CENTER, IT WILL NOT GO TO THE CENTRAL STATION, ALL SIGNALS AFTER THE FIRST ARE SENT TO THE CENTRAL STATION)

STEP 5: CONNECT SUPERVISORY TRIP OUTPUTS

Next, you will wire Telguard's supervisory trip outputs to the C/C and then test.

STEP 6: COMPLETE THE INSTALLATION

YOUR LAST STEP WILL BE TO CHECK THE JUMPER SETTING OF J10 (LED MODE, OPEN = NORMAL), ATTACH EARTH GROUND, AND PERMANENTLY MOUNT THE UNIT.

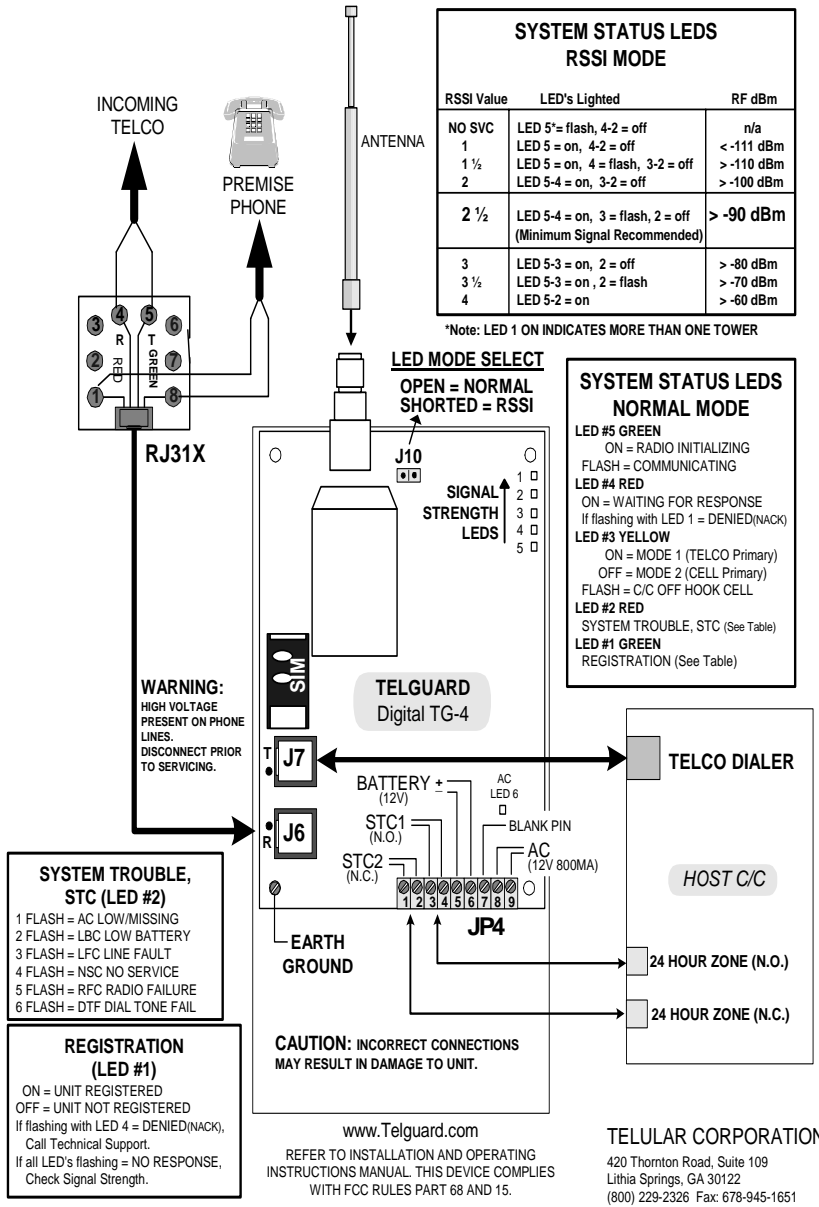

Setup & Programming the Operating Parameters in the Telguard Digital

When the Telguard is received from the factory and is powered up for the first time, it is immediately ready for registration, provided the default settings are what you want (note: activation form must be sent to Telular). The STC LED # 2 will flash to indicate any failure conditions. The Mode LED # 3 will be on and the STC 1 and STC 2 relays will be tripped. If changes are required to the default settings, the Telguard can be programmed using a line-mans butt-set connected to T & R Test Points or a POTS phone connected to J7 (black connector where the C/C is normally connected).

TO PROGRAM THE Telguard Digital

- A. Put the line-mans butt-set in talk mode or pick up the POTS phone.
- B. Connect power to the Telguard, when ready for programming you will hear 2 beeps.
- C. Press #, *, this will put the Telguard into a Master Access programming mode, 2 beeps.
- D. Enter changes required. The syntax for programming a specific memory location is as follows:
MEMORY LOCATION (3-digits), will respond with 2 beeps, then VALUE, will respond with 2 beeps.
- E. Then press *, you will hear 2 beeps then hang up. This saves the change and exits the programming mode.

MEM LOC.	FIELD	DEFAULT	SETTING
831	Mode of operation	1	1= Telco Primary/Cellular backup 2 = Cellular Primary/Telco Backup
833	C/C Reporting Format	09	01= 4x2 pulse, 40pps 2300 hz 02= 4x2 pulse, 20pps 2300 hz 03= 4x2 pulse, 20pps 1400 hz 04= 3x1 pulse, 40pps, 2300 hz 05= 3x1 pulse, 20pps, 2300 hz 06= 3x1 pulse, 10pps, 1400 hz 07= Radionics IIe or IIIa ² 08 = Contact ID 09 = Auto Format Detect 11 = SIA2 (300 Baud) 12 = DMP
850	STC 1 Trip Output Reporting Normally Open	04	Enter the SUM TOTAL of the events that you wish to trip the STC relay by ADDING the corresponding values: 00 = STC Trip Input Not Used 01 = AC Failure 04 = LFC 16 = RFC 02 = Low Battery 08 = NSC 31 = All
851	STC 2 Trip Output Reporting Normally Closed	27	Enter the SUM TOTAL of the events that you wish to trip the STC relay by ADDING the corresponding values: 00 = STC Trip Input Not Used 01 = AC Failure 04 = LFC 16 = RFC 02 = Low Battery 08 = NSC 31 = All
852	STC Trip Delay for LFC and NSC	2	1=30 Seconds 6=30 minutes 2=60 Seconds 7=45 minutes 3=3 minutes 8=60 minutes 4=10 minutes 9= 24 hours 5=20 minutes
861	CFC Number of Events	0	0 = disabled 2 = 4 attempts 1 = 2 attempts 3 = 8 attempts
862	CFC between Events	1	1 = 30 seconds 3 = 70 seconds 5 = 90 seconds 2 = 60 seconds 4 = 80 seconds 6 = 99 seconds
872	AC Failure Delay	02	0-24 hours, default = 2 hours
899	Factory Default Unit		

NOTE: SPECIAL LED INDICATIONS DURING ACTIVATION

If the Telguard fails to confirm registration it will be displayed on the LEDs:

SYSTEM STATUS LEDES	REGISTRATION INDICATIONS
ALL LEDES FLASHING	FAILED REGISTRATION – SIGNAL TOO WEAK
LED #1 & LED #4 FLASHING	REGISTRATION ERROR – CALL TECH SUPPORT
LED #1 ON	REGISTRATION SUCCESSFUL
LED #2 ON SOLID NOT REGISTERED	NEED TO CONNECT PANEL AND TRIP ZONE

On either a **FAILED** or **REGISTRATION ERROR**, the unit **MUST BE RESET BY PUTTING THE J10 (RSSI jumper) in the 'SHORTED' position. The registration message MUST BE RESENT** or the TELGUARD will transmit all signals through the telco connection.