



Wi PATH™ SX7 EVDO

Quick Start Guide

Unpack the Box

- Your Wi PATH™ SX7
- 2 TNC Antennas
- Power Supply Adapter
- Power Line Cord
- Rechargeable Battery Pack
- Ethernet Cable (RJ-45)*
- USB Cable*
- RJ-11 Phone Cable (SX7T only)*
- Quick Start Guide (this guide)*
- CD (contains User Guide and support materials)*

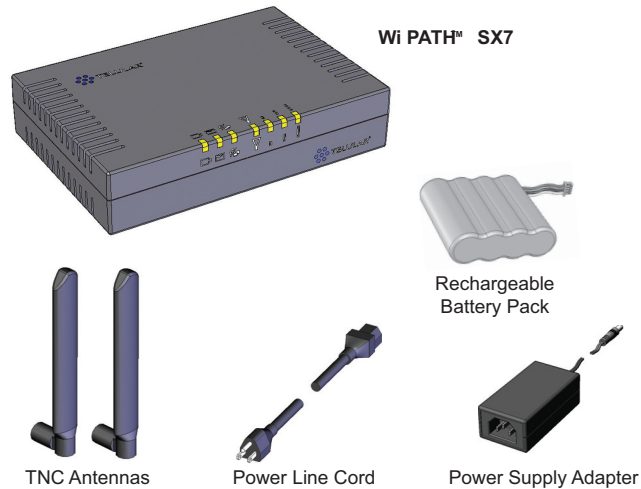

(* – not pictured)

Make sure you have everything listed before continuing. If any items are missing or damaged, please contact your authorized distributor for assistance.

Set Up the SX7

1. Install the **Rechargeable Battery Pack** into the battery compartment. Remove the battery compartment door, insert the battery connector into the battery terminal, arrange the battery pack in the compartment, and replace the battery compartment door. *(As pictured below, the rounded corner of the battery connector will be on the left side.)*

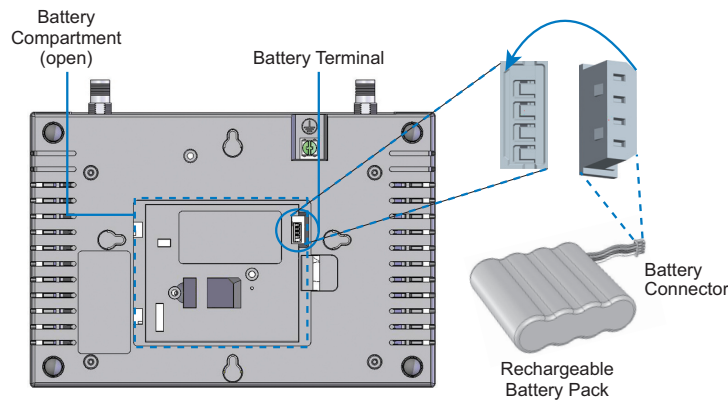

2. Connect and hand-tighten the **TNC Antennas**. Once they are installed, arrange the antennas so they point upward (vertical orientation).

3. Connect the **Power Supply Adapter** to the unit's Power Input and connect the **Power Line Cord** to the Power Supply Adapter. Then, connect the Power Line Cord plug into a power outlet.

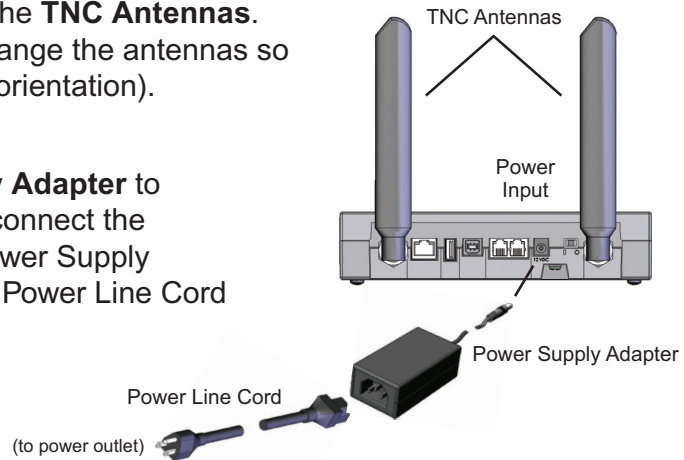

4. Connect the **Ethernet (RJ-45)** cable to the Ethernet Port on the SX7. Then, connect the other end of the Ethernet cable to an available Ethernet port on your computer.

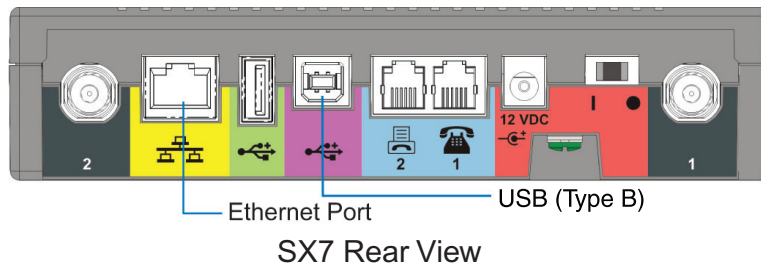

Note

It is recommended that you use the Ethernet Port to establish the connection between your SX7 and your computer. You may also use the supplied USB cable. Please see the **User Guide** on the CD for instructions on setting up your computer to use a USB connection.

5. (*SX7T model only*) Connect an **RJ-11 Phone** cable from a standard phone to the Phone input (J1), and connect another RJ-11 cable from a compatible fax machine to the Phone/Fax input (J2), if applicable.

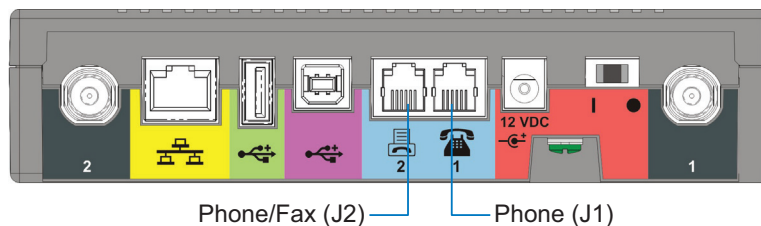

Note

Voice, Fax, and Circuit Switched Data service must be provisioned on your account and supported by your wireless service provider to function properly. Please see the **User Guide** on the CD for instructions on setting up your RJ-11 Phone and Phone/Fax jacks.

Power up the SX7.

1. With the SX7 powered off, make sure the Ethernet (or USB) cable is connected to both the SX7 and the computer, and then power on the computer.

- Slide the SX7 Power Switch to the **On** position, from right to left (as pictured).

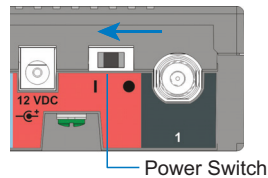

- Wait a few minutes for the SX7 to initialize. Once the Signal Strength LEDs are illuminated, you are ready to proceed.

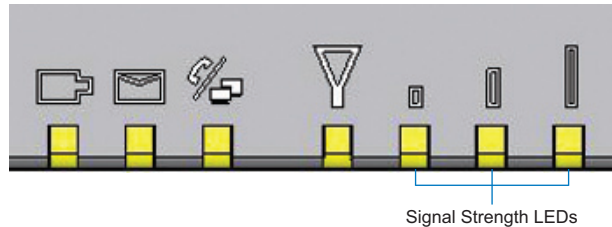

Activate Your Wireless Services on the SX7

- When all devices are connected and powered on, use your computer to connect to the **Telular Device Manager**.

- Launch your Web browser (Internet Explorer or FireFox).
- Go to the browser's address bar, type **<http://192.168.1.1>**, and press **Enter** or click the green Go arrow. A "Connect to" window will be displayed.
- Enter the default **User name** ("telular") and **Password** ("1234"). The **Telular Device Manager** will start and display the Home screen.



Tip Bookmark the **Telular Device Manager** access page (<http://192.168.1.1>).

- From the Home screen, click **Activation** (1) and wait 5–10 minutes to see if your unit will auto-register itself on the wireless network. If the **Activation Status** field (2) displays **ACTIVE**, your SX7 is ready for use. Proceed to **Set Up a Wireless WAN Data Connection**.

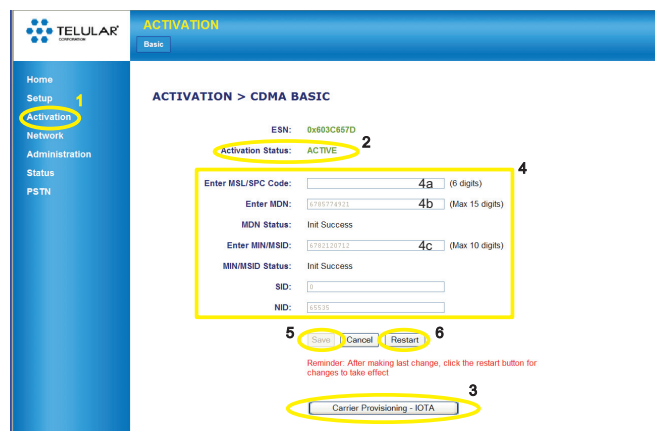

3. If your SX7 is not active, click **Carrier Provisioning – IOTA** (3) to initiate “over-the-air” provisioning by your wireless service provider. Check the **Activation Status** display (2) to check your status.
4. If your service provider does not offer IOTA provisioning, manually enter your **MSL/SPC Code** (4a), your **MDN** (10-digit wireless phone number) (4b), and your **MIN/MSID** (usually also your 10-digit wireless phone number) (4c). Contact your wireless service provider for your account settings.
5. Click **Save** (5). If you have no additional changes, click **Restart** (6) to complete Activation. The SX7 will power down and restart.

Tip

When adding or changing settings in the **Telular Device Manager**, click **Save** whenever you change a setting, and then move on to the next item you want to change. When you have finished making all your changes, click **Save** again and then click **Restart**. The SX7 will power down and restart, and all your new settings will be in effect.

Set Up a Wireless WAN Data Connection

1. From any page in the **Telular Device Manager** (see previous step 1), click **Setup** (1) > **Wireless WAN** (2).

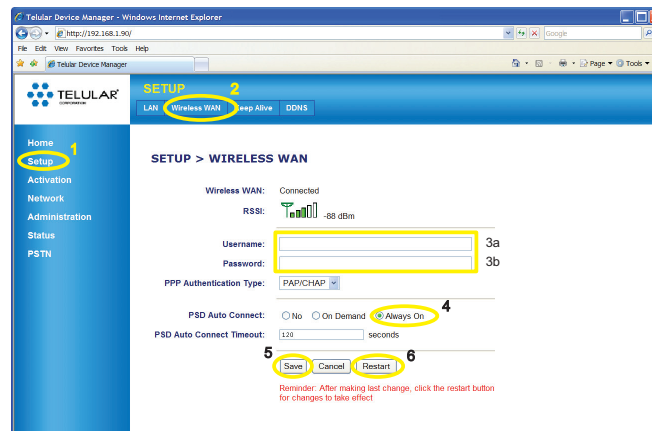

2. If required by your wireless service provider, enter your **Username** (3a) and **Password** (3b).
3. Click **Always On** (4) next to **PSD Auto Connect**.
4. Click **Save** (5) and **Restart** (6) to complete Setup. The SX7 will power down and restart, and you will be ready to connect to the Internet.

Mounting your SX7 to the wall

Caution

When mounting the SX7 to the wall using screws, be careful **NOT** to allow the screw heads to push the plastic tabs inward towards the SX7. A potential to short circuit the unit may occur should the plastic tabs make contact with the internal printed circuit boards.

For additional details on the SX7 and advanced settings, please see the User Guide on the CD that is packaged with your device.